

BRICKS CATALOGUE



GOOD HAND
STONES AND CONCRETE FLOORING L.L.C

GHome
WHERE 'YOU' MATTER



Click here

@goodhandscf

Showroom No-01, Al Falasi Building,
Salaheldin Street Deira, Dubai-UAE

Click here



@ghomeuae

+971 4 262 2888

Click www.goodhandpro.com to visit

About Us: Crafting Beauty in Concrete and Bricks Showroom!

At Good Hand Stones and Concrete Flooring LLC., we are passionate about transforming ordinary spaces into extraordinary masterpieces. Our showroom is your gateway to a world where creativity meets craftsmanship, and where your imagination comes to life through the versatility of decorative concrete and bricks.

Established with a vision to redefine the landscape of architectural design, we pride ourselves on delivering excellence through our unparalleled products. Good Hand SCF has been a pioneer in the industry for 10 years. We are more than just manufacturers; we are creators, innovators, and collaborators, dedicated to delivering excellence in every project.

Step into our showroom and immerse yourself in a diverse range of decorative concrete and bricks options. From sleek and modern designs to rustic and traditional aesthetics, we offer an extensive selection to suit every style and preference. Whether you're looking to enhance your home, office, outdoor area, or commercial space, we have the perfect solution for you.

What sets us apart is our relentless pursuit of perfection. Each of our concrete and brick creations is meticulously crafted by skilled artisans who pour their expertise and passion into every detail. From intricate patterns to bold textures, our products exude character and charm, breathing life into any environment they grace.

Moreover, sustainability lies at the heart of everything we do. We are committed to eco-friendly practices, using responsibly sourced materials and employing innovative techniques to minimize our environmental footprint. By prioritizing sustainability, we not only protect the planet but also ensure that our creations endure for generations to come.

Our Products:

Explore our comprehensive range of products, including:

- Exposed Aggregate Concrete
- Stamped Concrete
- Bricks
- Micro Topping
- Pool Renders
- Stones
- Tiles
- Sanitary Ware
- And much more!

Visit Us Today:

Experience the endless possibilities of decorative concrete and bricks firsthand at Good Hand SCF Showroom. Whether you're a homeowner, architect, designer, or contractor, We invite you to unleash your creativity and explore the limitless potential of our Products.

Transform your space with Good Hand SCF—where innovation meets imagination, and ordinary becomes extraordinary. We look forward to welcoming you soon!



DID YOU KNOW ?

Every day, Good Hand Stones and Concrete Flooring makes a big difference by actively contributing to an 82% decrease in CO2 emissions, helping protect the ozone layer and lower greenhouse gases. Our commitment to sustainability ensures a healthier future for all. Plus, we're proud to say that unlike others, we don't use ovens for our bricks, further reducing our environmental footprint.

"Bricks are available in several colors and textures."

GOOD HAND
STONES AND CONCRETE FLOORING L.L.C

"Our bricks are made in UAE."



INDEX

Licences & Certifications

Membership Certificate	01
ISO Certificate	02

Bricks Catalouge

Antique & Plain Bricks	03-19
------------------------	-------

Technical Data Sheet

Product Description	20
Installation	21
Wet Fixing	22
Materials Percentage & Testing	23

How we turned dreams into reality, brick by brick

Brick work inside Mall of the Emirates	24
Brick work at Yas Mall Abu Dhabi	24
Brick work at Dubai Mall	25
Brick work Inside Ibn e Batuta Mall	25
Brick work at Marina Home	26
Brick work Inside The Galleria Mall	26
Brick work at Bla Bla JBR Dubai	27
Brick work at Yas Island Abu Dhabi	28
Brick work at Meenar Cafe Jumierah Lake Towers	28
Brick work in Studio City	29
Brick work at Anbar Resturant & Cafe in Business Bay	29
Brick work in Abu Dhabi	30
Brick work at TGL Friday Jumierah	31
Brick work at society motors Dubai	31

شهادة تسجيل العضوية Membership Certificate

License no.	892971
Membership no.	340470
Registration no.	1499908
Trade Name	GOOD HAND STONES AND CONCRETE FLOORING L.L.C
Legal Status	Limited Liability Company(LLC)
Activity	Technical Services Works Electromechanical Works Contracting
Member Since	30/06/2020
Date of Issue	30/06/2020
Expiry Date	29/06/2024

رقم الرخصة	892971
رقم العضوية	340470
رقم السجل التجاري	1499908
الاسم التجاري	جود هاند للأحجار و الأرضيات الخرسانية ذ. م.م
الشكل القانوني	ذات مسؤولية محدودة
نوع النشاط	أعمال الخدمات الفنية مقاولات الأعمال الإلكترونية وميكانيكية
تاريخ الإنتساب	30/06/2020
تاريخ الإصدار	30/06/2020
تاريخ الإنتهاء	29/06/2024

Remarks

This certificate shall be invalid incase of any alteration without chamber's authorization

For online verification of this Certificate, please visit our website

<http://www.dubaichamber.ae/verify>

غرفة تجارة وصناعة دبي
Dubai Chamber of Commerce & Industry

هاتف (+971) 4 2280000 | Tel (Within UAE) 800 CHAMBER (800 2426237) | P.O. Box 1457 - Dubai, U.A.E.

فاكس (+971) 4 2211646 | customercare@dubaichamber.ae | www.dubaichamber.ae

الملاحظات

تعتبر هذه الشهادة لاغية في حال أي كسب أو تعديل عليها دون اعتماد ذلك من الغرفة

للتأكد من صحة بيانات الشهادة يرجى الرجوع إلى موقع الغرفة

<http://www.dubaichamber.ae/verify>



Certificate

This is to Certify that
**Good Hand Stones and Concrete Flooring
LLC**

Showroom No 1, Good Hand Stones And Concrete Flooring
L.L.C, Al Falasi Building - Salah Al Din St - Dubai, UAE

has been found in Compliance with requirements of

**Quality Management System
ISO 9001:2015**

for the following scope:

**Deals in Exposed Aggregate, Stamped Concrete, Bricks, Micro Topping,
Pool Render System, Color Plaster, Repair and Restoration of Decorative
Concrete, Tiles and Sanitary Ware.**

Certificate No. : QCC/95C9/0224
Issue Date : 26-February-2024
1st Surveillance Due : 25-January-2025
2nd Surveillance Due : 25-January-2026
Expiry Date : 25-February-2027

Authorized Signature

Quality Control Certification

To check this certificate status visit:
["https://qccertification.com/Client.aspx"](https://qccertification.com/Client.aspx)



EAS is member of International Accreditation Forum (IAF)

"Quality Control Certification (QCC)" accredited by "Ethiopian Accredited Service (EAS)".
This certificate remains the property of "QCC" to whom it must be returned on request.

Ecological Thin Brick

Plain Bricks

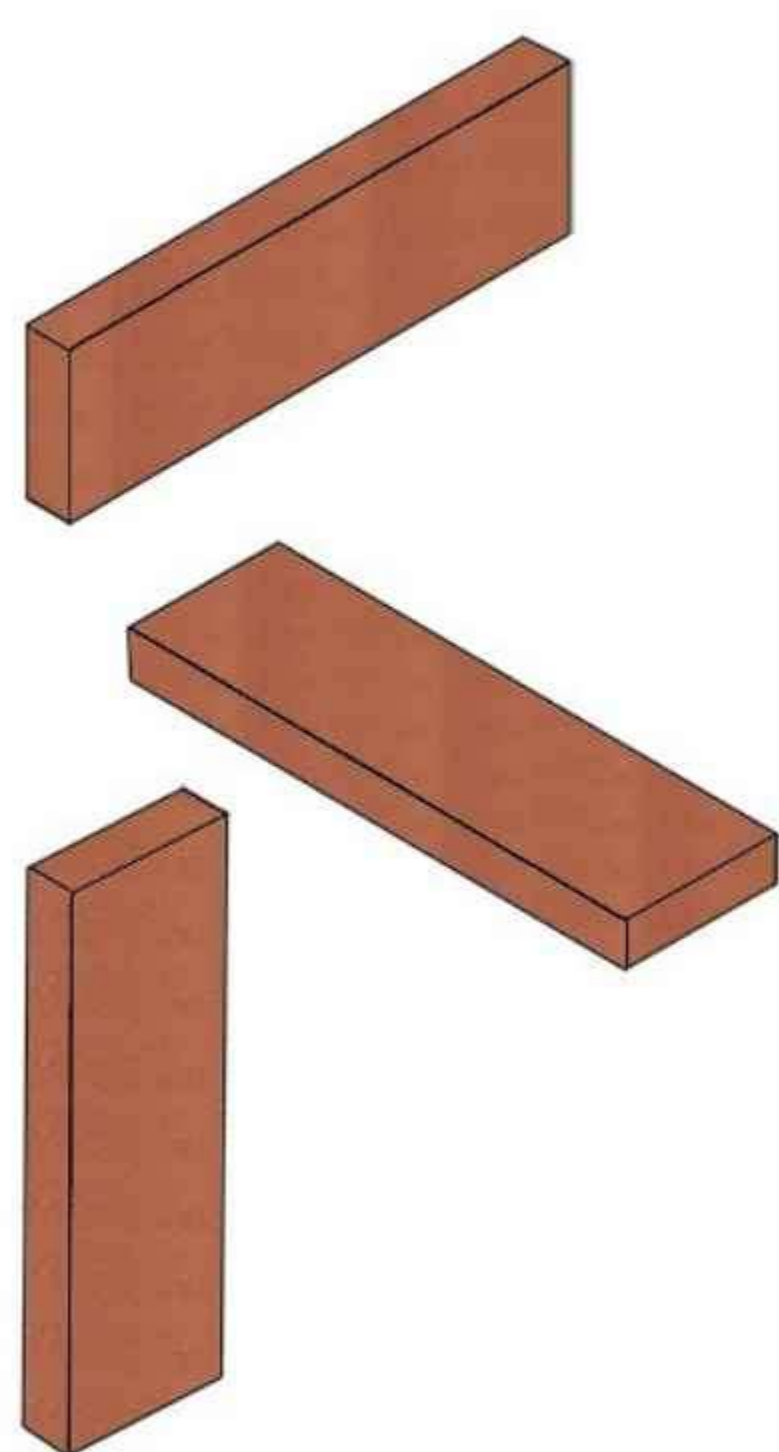
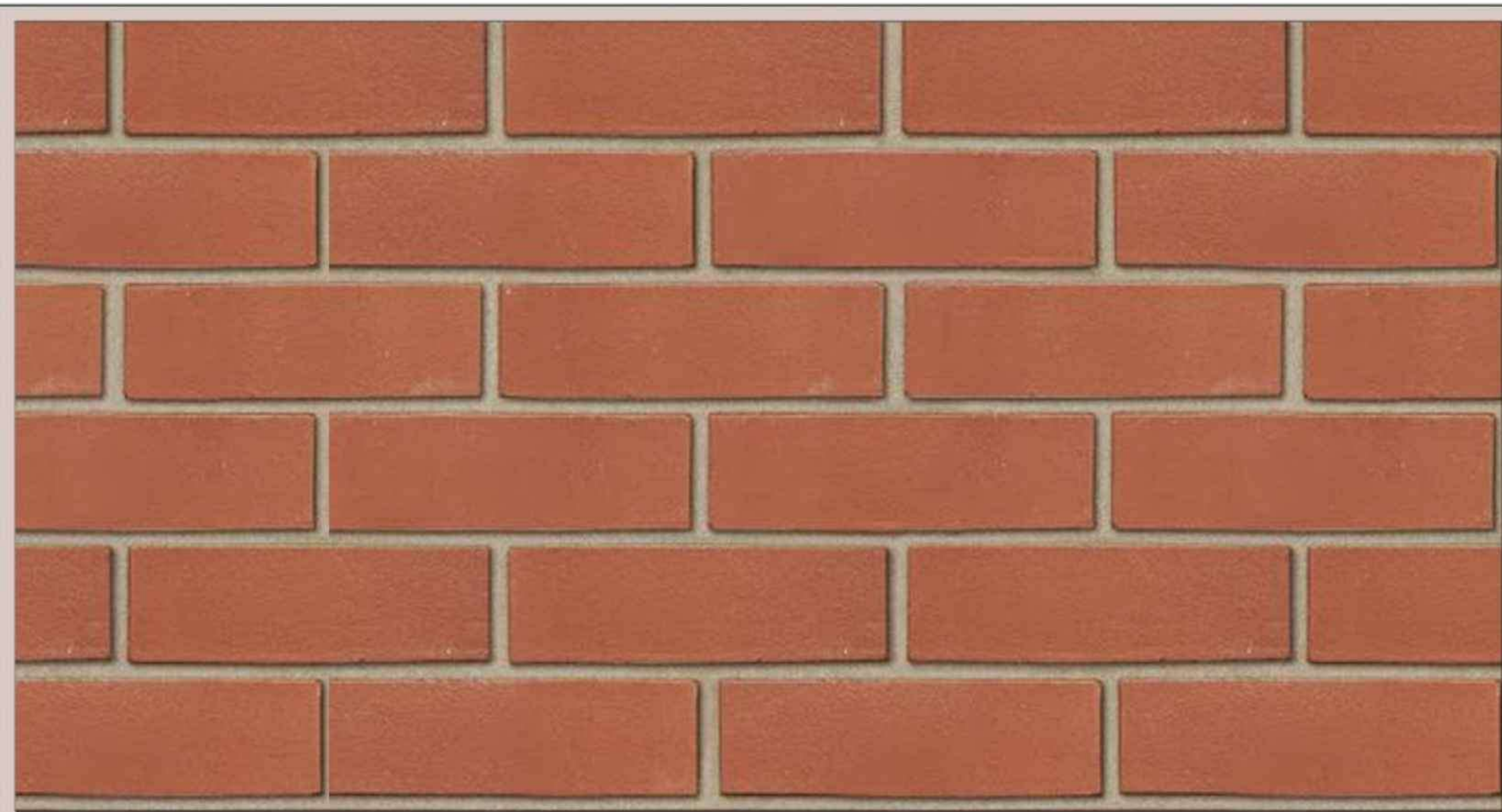

Technical Specifications:

Weight per m2 = 24 kg Approx:

Dimensions:

Height = 6.5cm

Width = 20.5cm

Thickness = 1.5-2cm

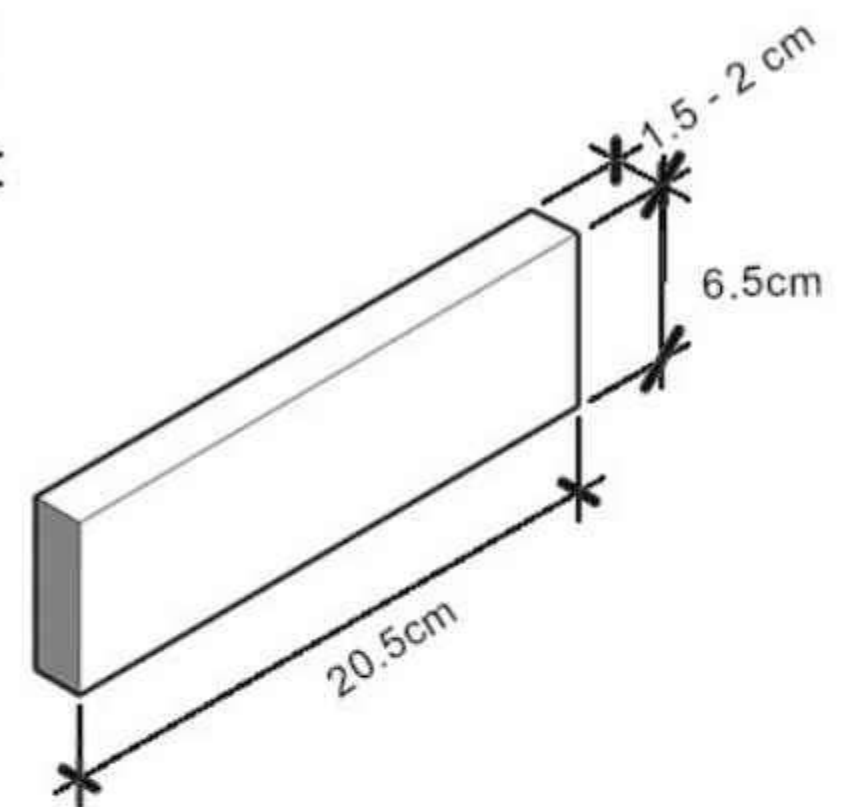

Applications:

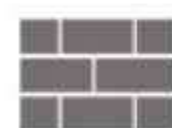

Outdoor Areas

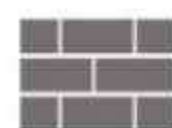

Indoor Areas

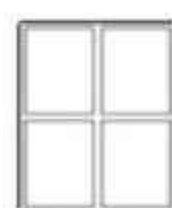

With Grout

Without Grout

Ecological Thin Brick

Antique Bricks

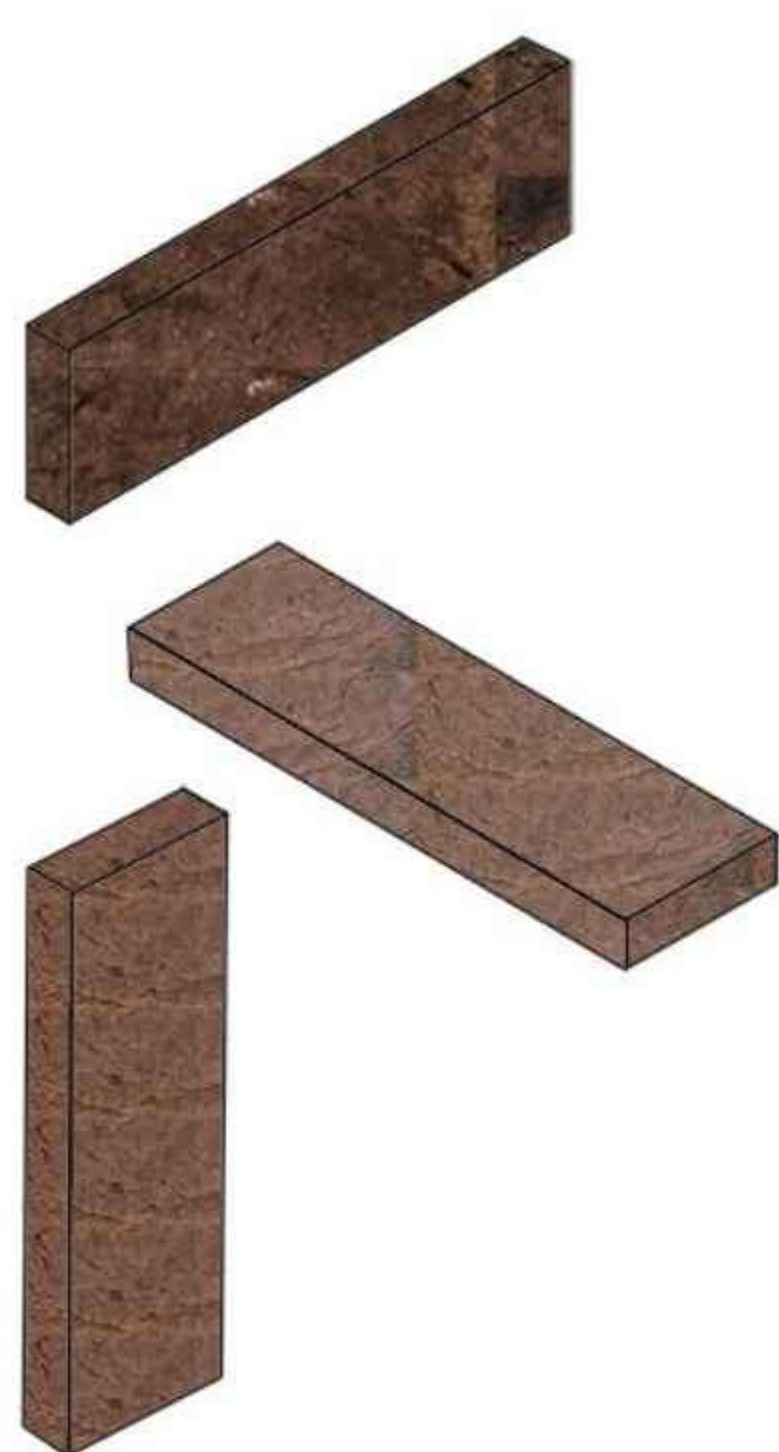

Technical Specifications:

Weight per m2 = 24 kg Approx:

Dimensions:

Height = 6.5cm

Width = 20.5cm

Thickness = 1.5-2cm

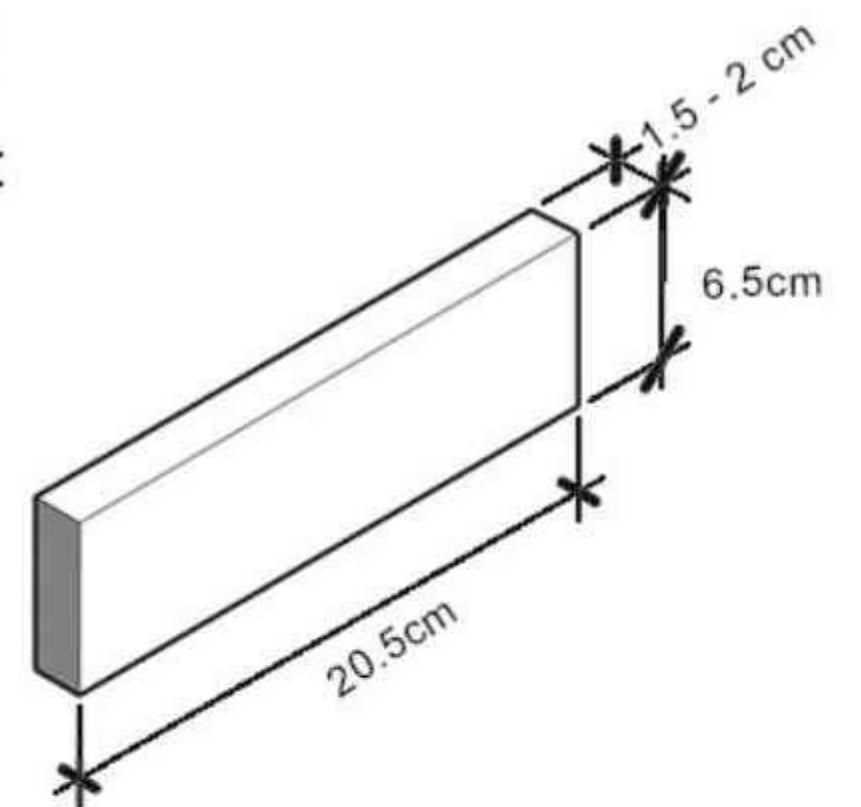

Applications:

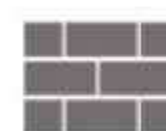
 Outdoor Areas

 Indoor Areas

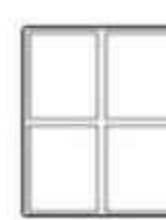
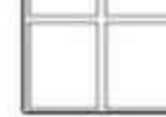
 With Grout
 Without Grout

Plain Bricks

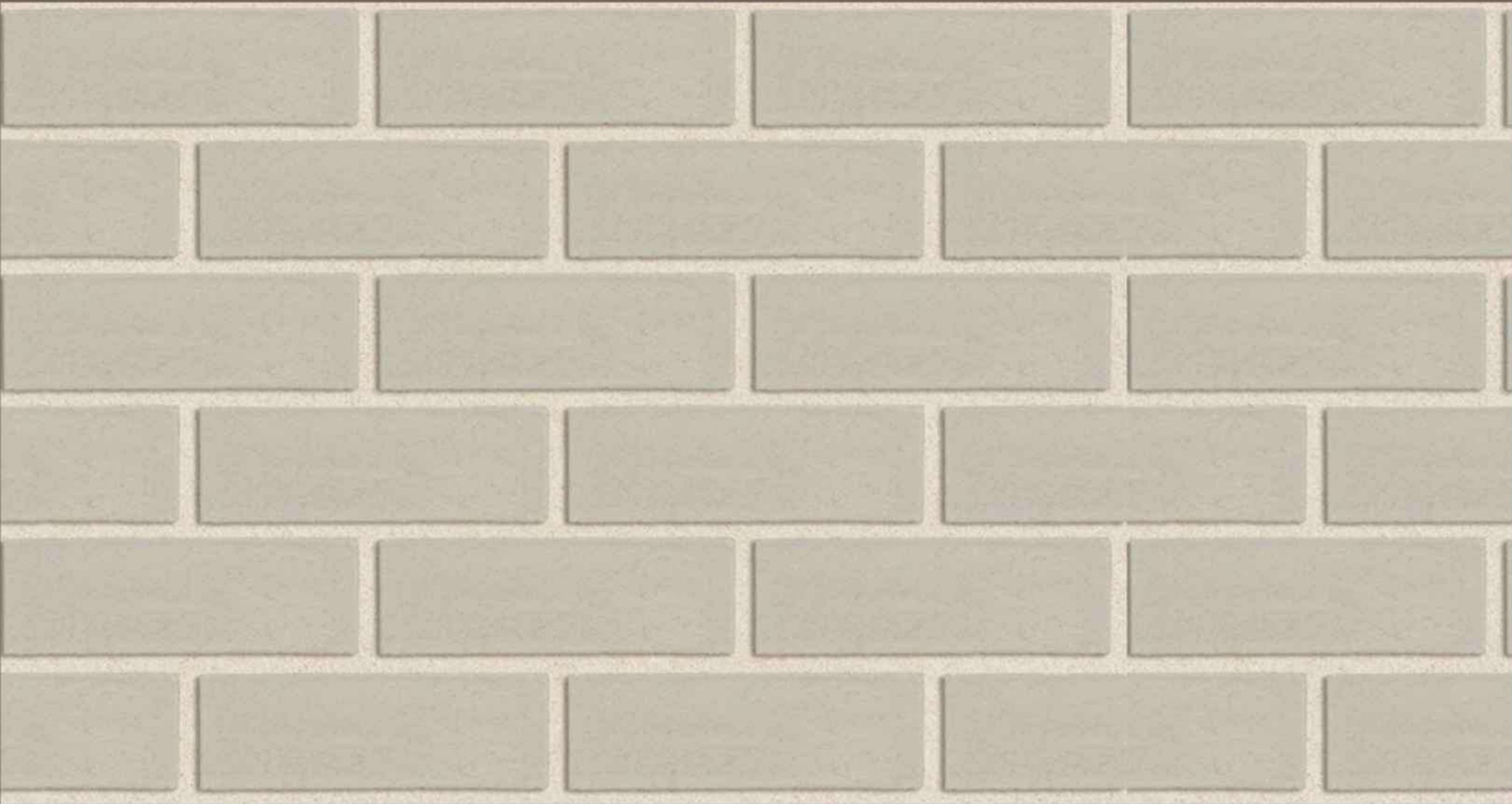

Antique Bricks



Plain Bricks

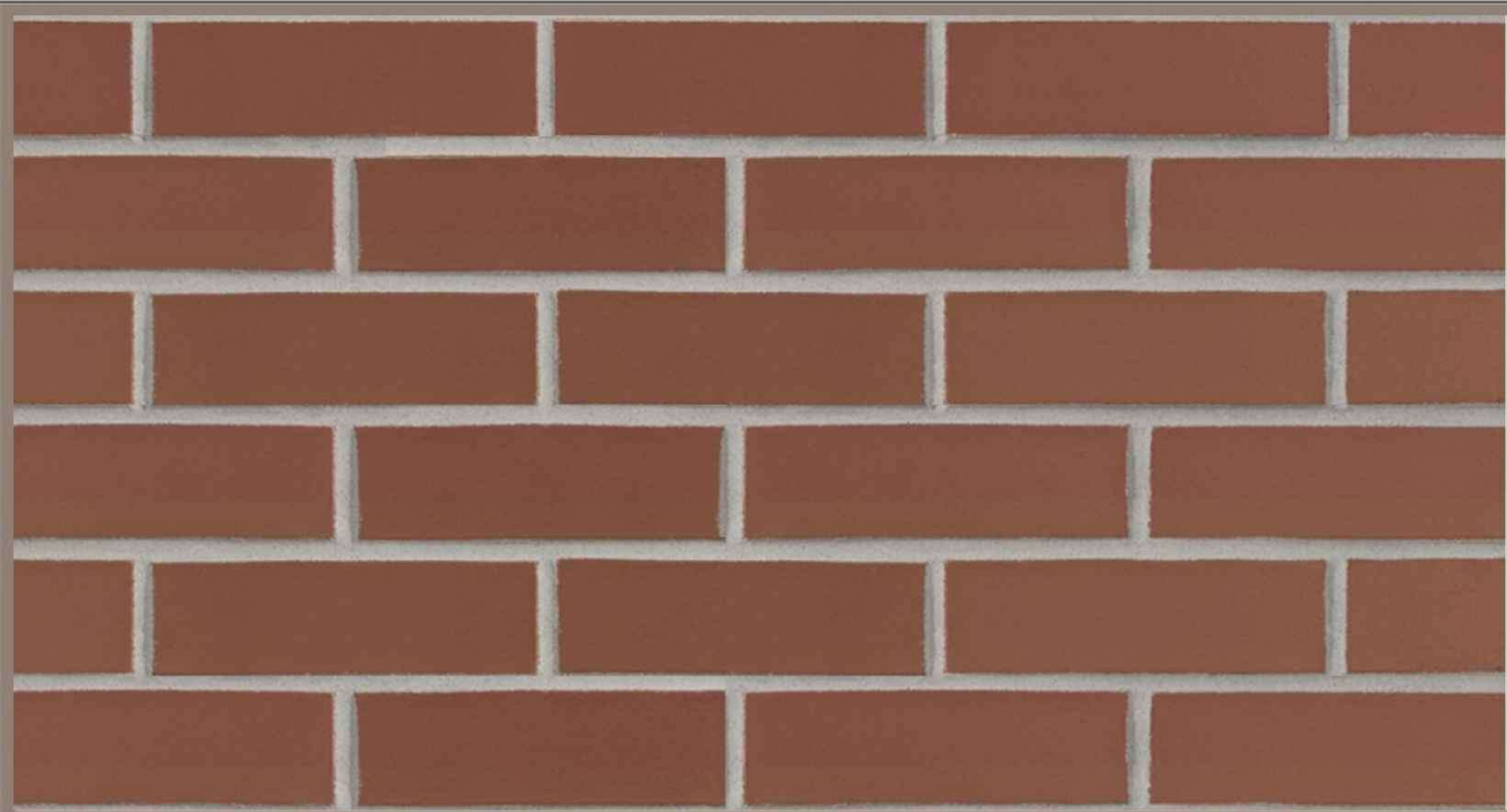

Antique Bricks



Plain Bricks

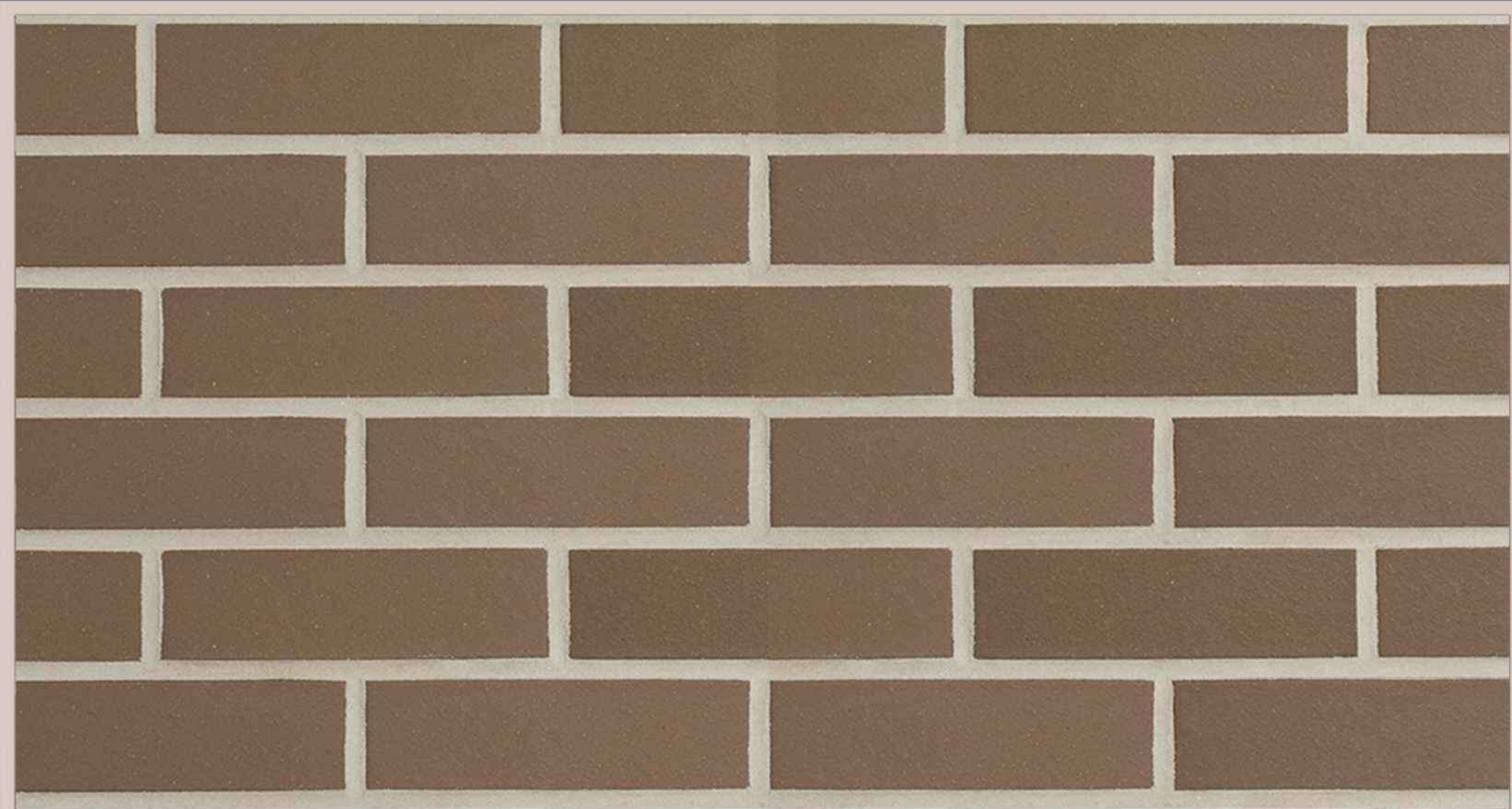

Antique Bricks

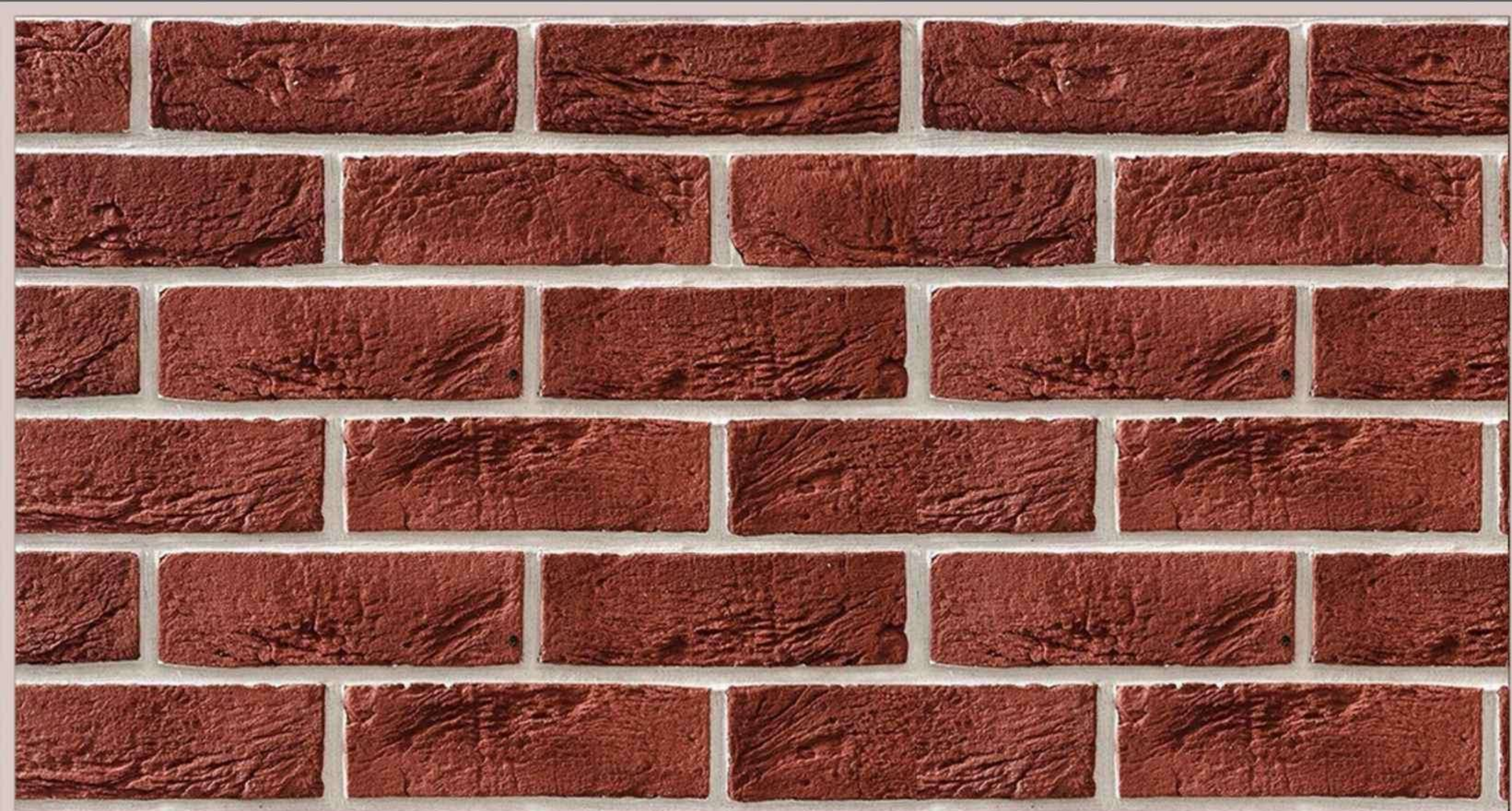

Plain Bricks

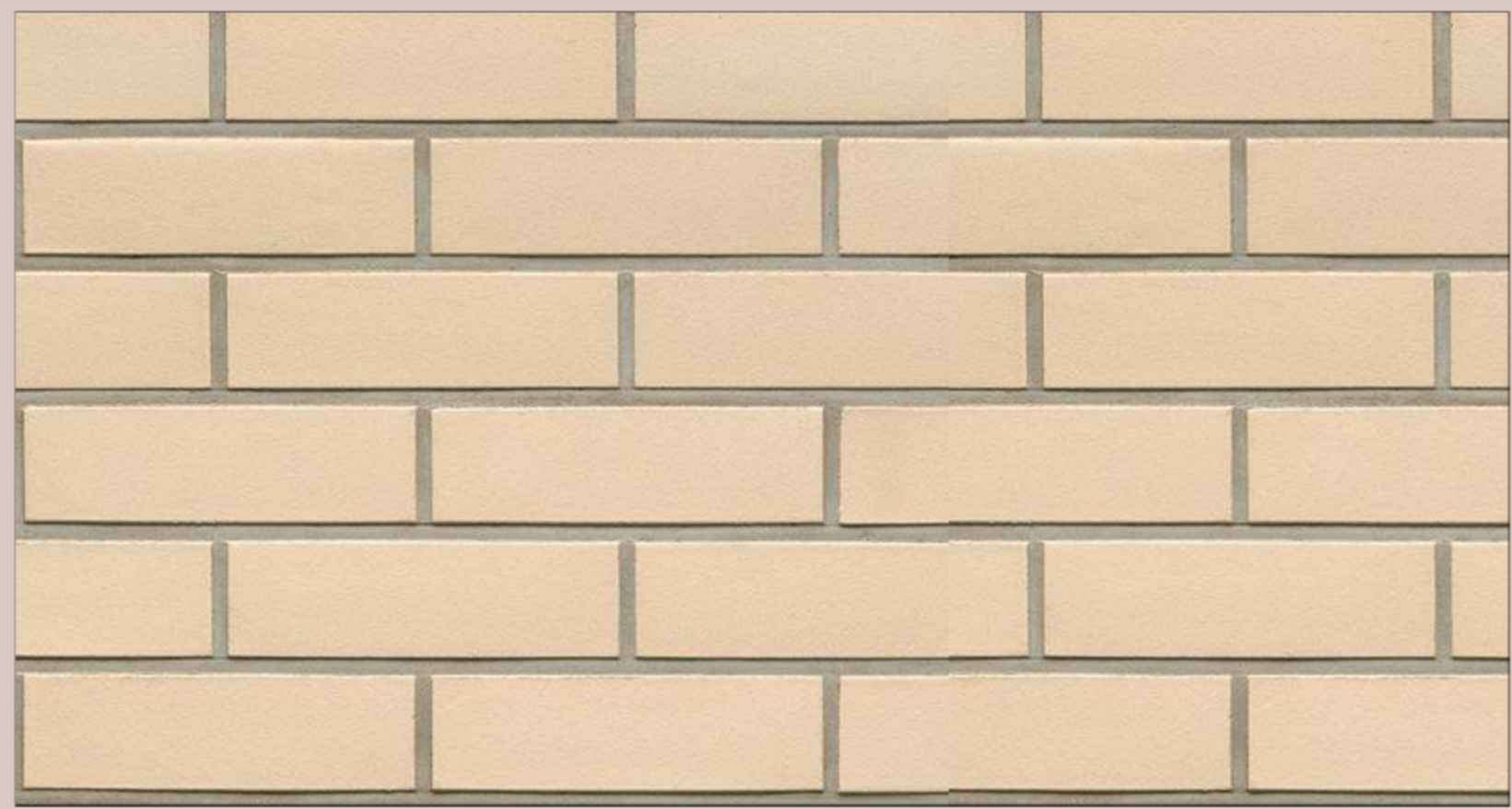

Antique Bricks

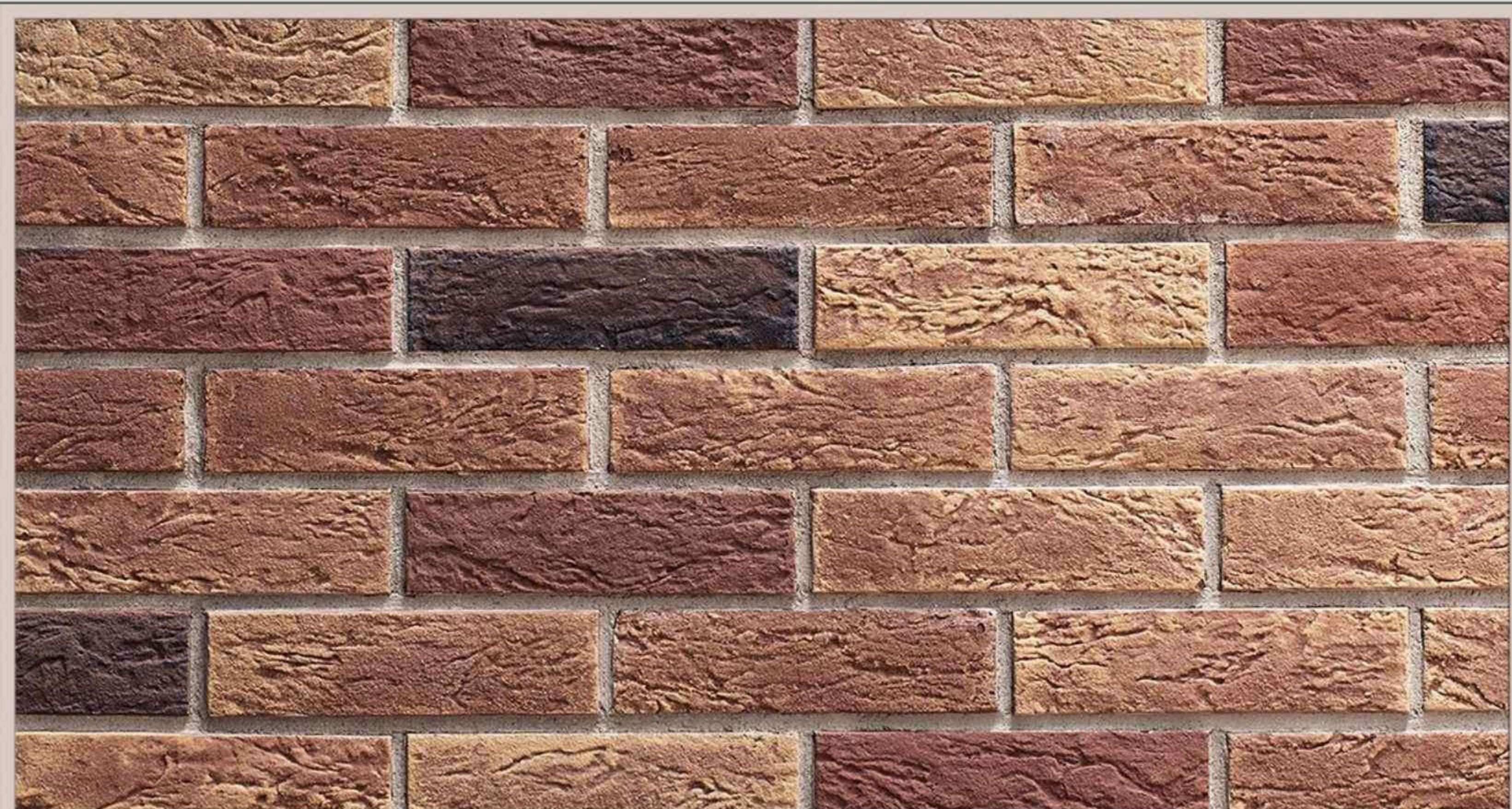

Plain Bricks

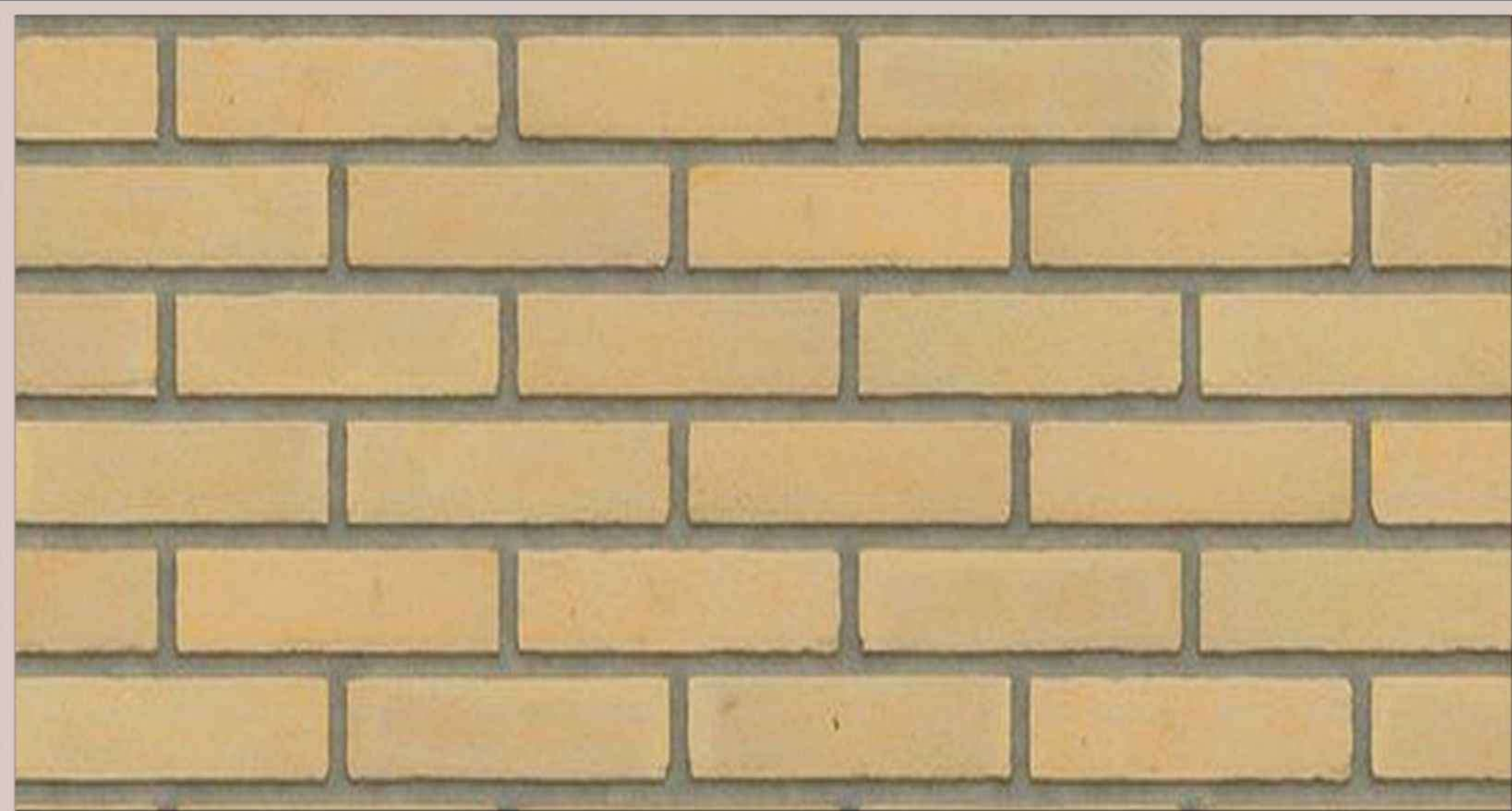

Antique Bricks



Plain Bricks



Antique Bricks

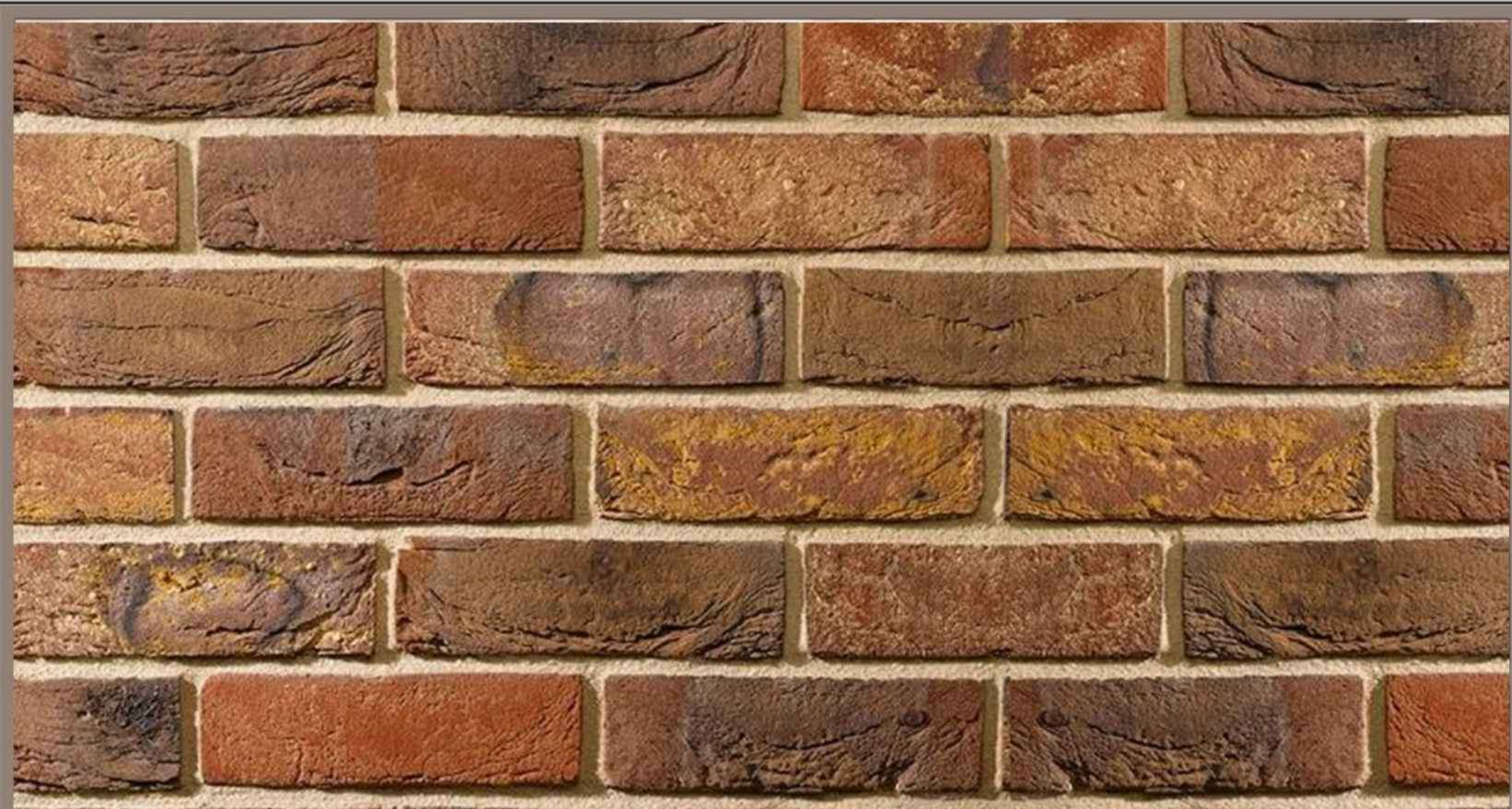

Plain Bricks



Antique Bricks

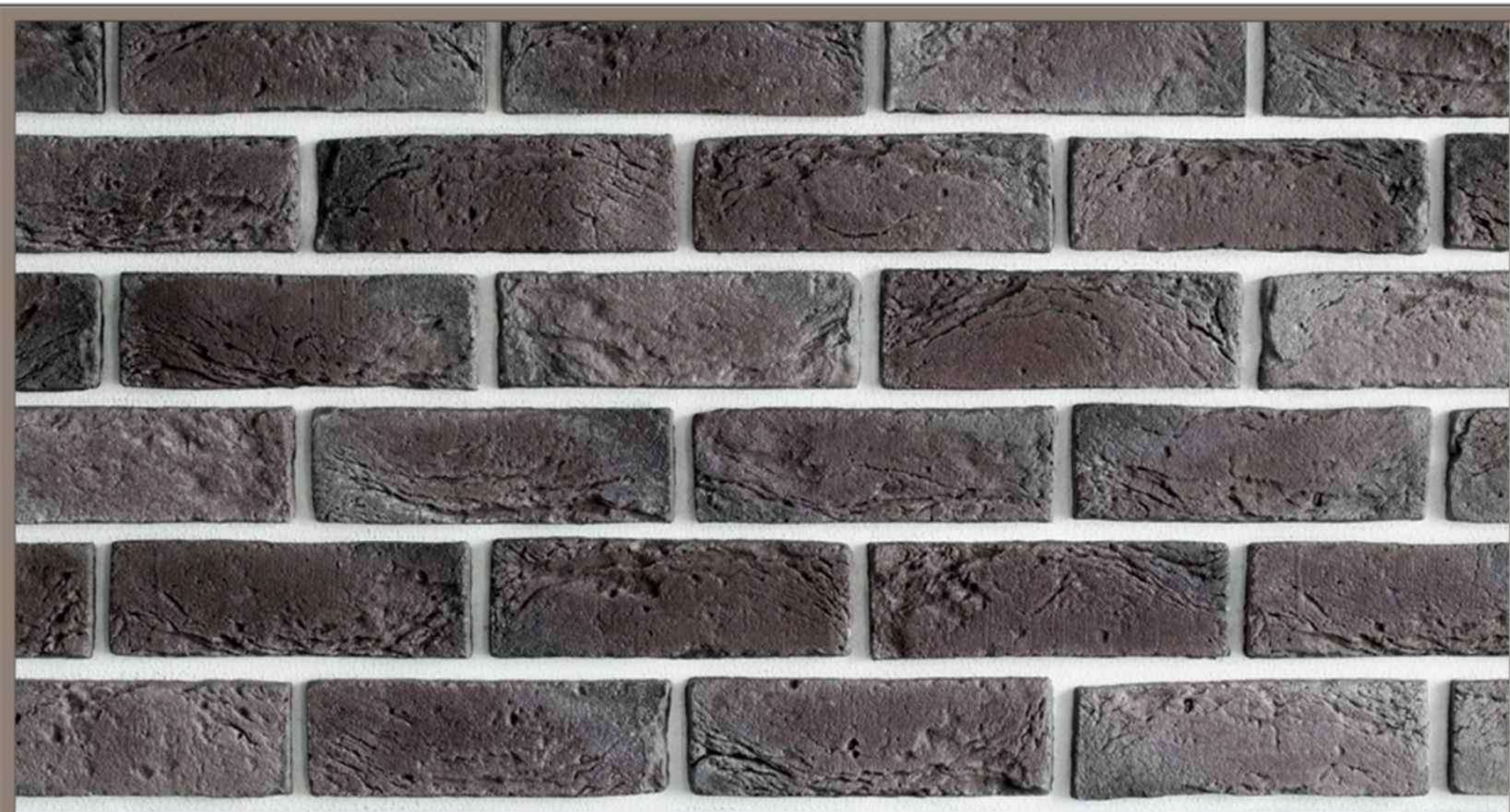

Plain Bricks



Antique Bricks

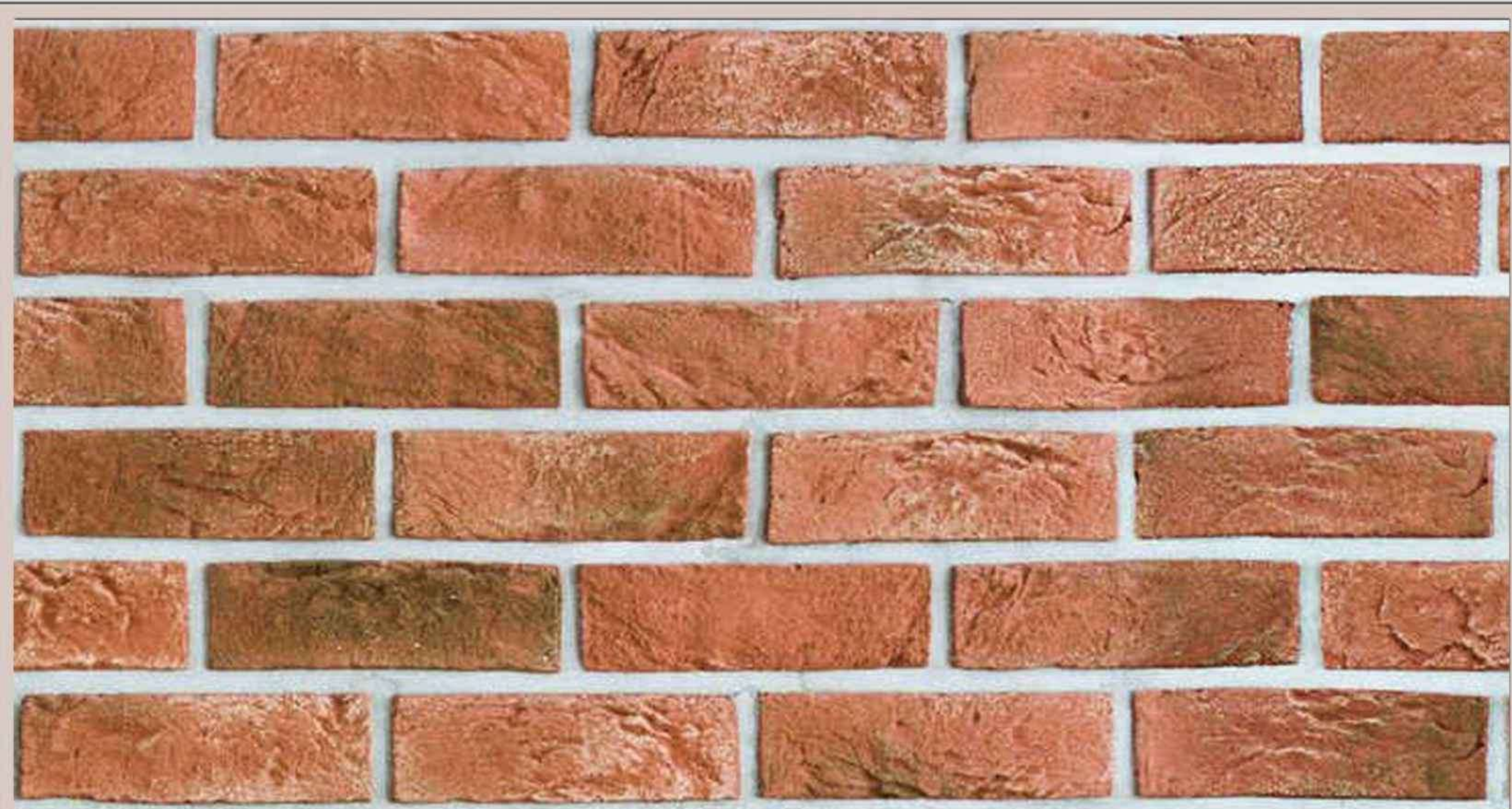

Plain Bricks

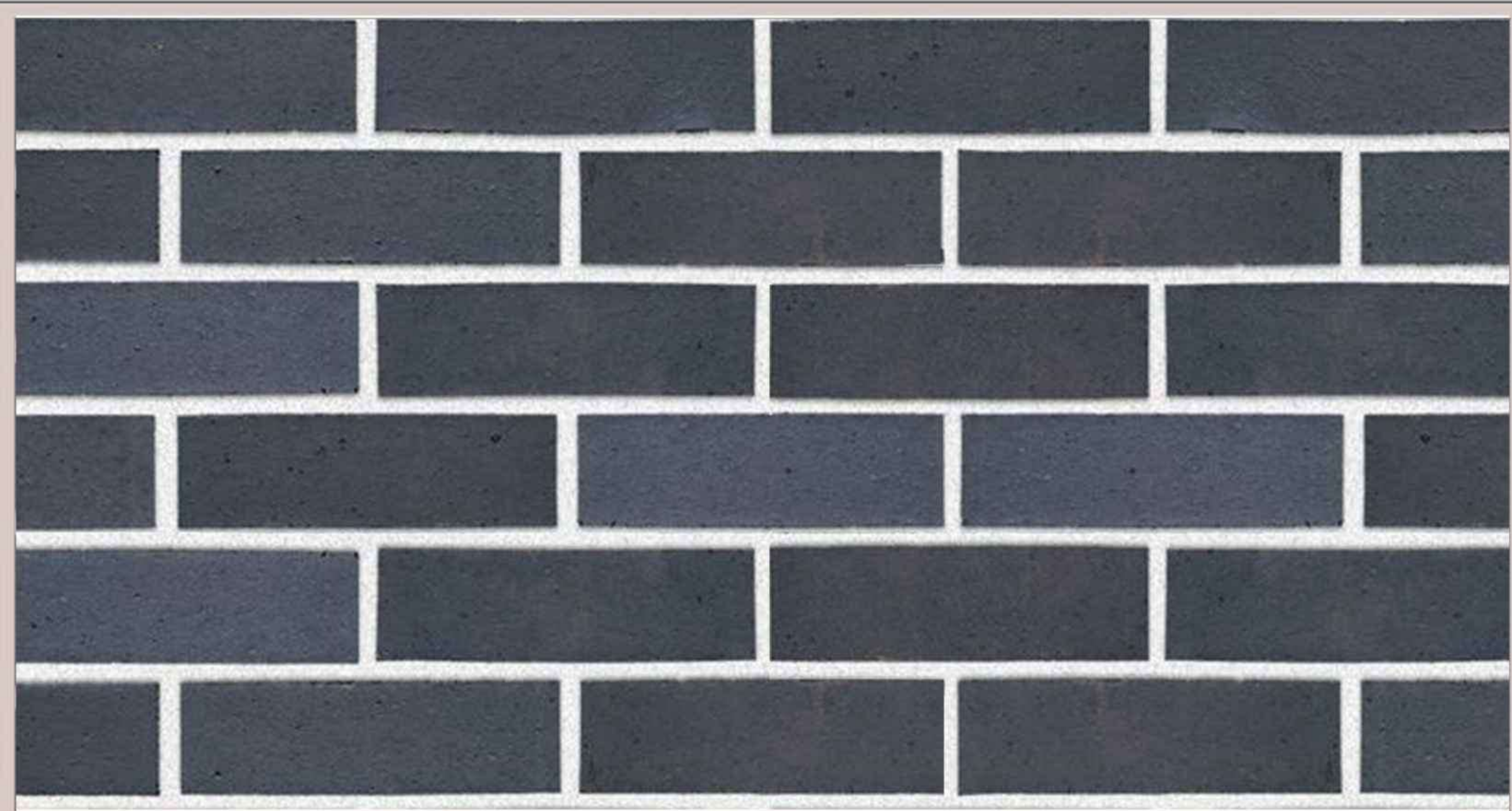

Antique Bricks



Plain Bricks

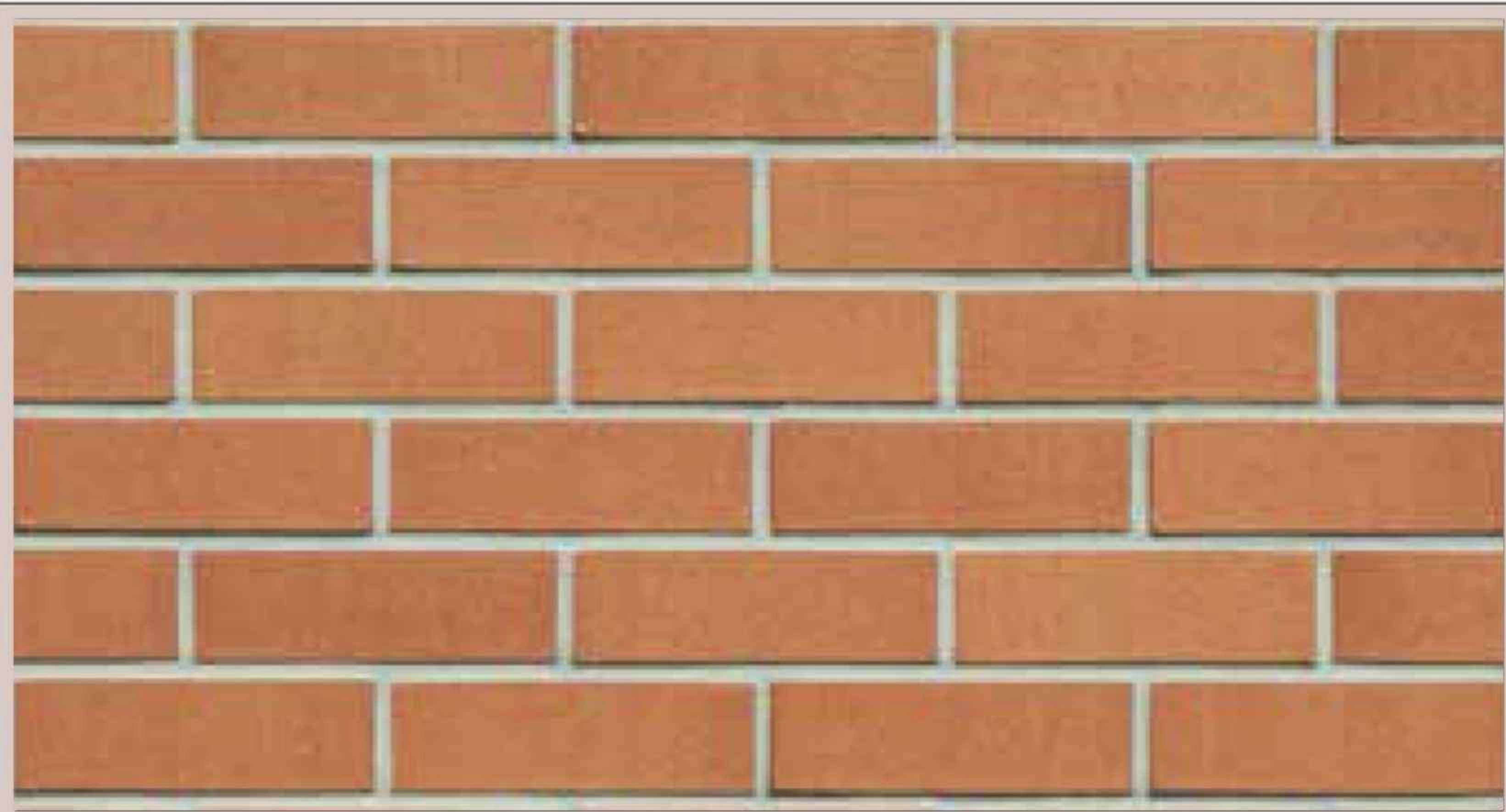

Antique Bricks



Plain Bricks



Antique Bricks



Plain Bricks

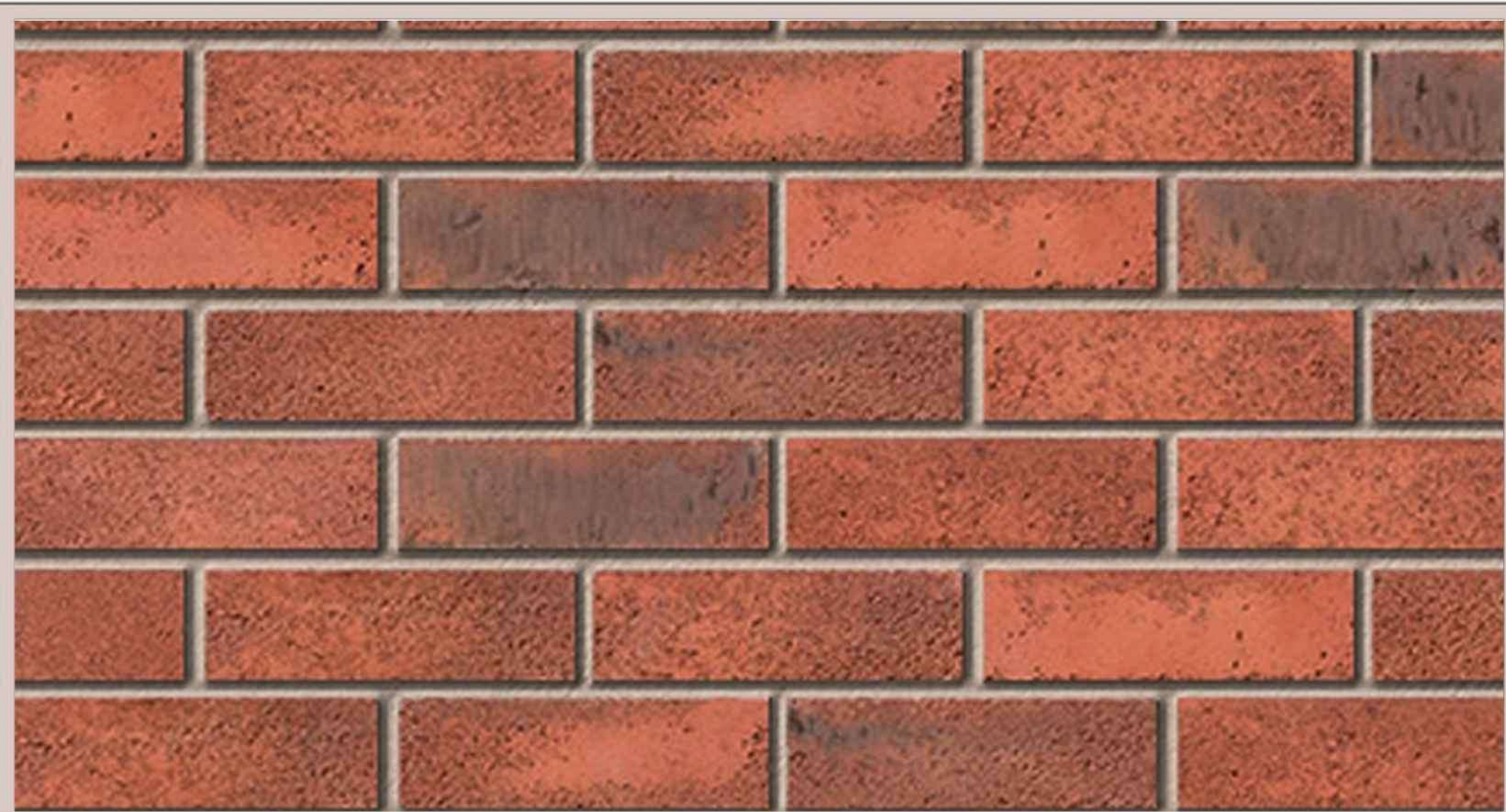

Antique Bricks



Plain Bricks



Antique Bricks



Plain Bricks



Antique Bricks



Plain Bricks



Antique Bricks



Technical Data Sheet

Product Description

Bricks are designed for cladding use over existing concrete and masonry. Bricks are a blend of micro silica aggregates, Cement, white sand, German colour pigments, and various additives that produce Bricks. Bricks come in different textures, colours, and patterns to replicate a wide variety of finishes such as brick, tile, slate, and more. Once sealed, Bricks are virtually water-impermeable, allowing it to be used in areas where water would otherwise pose a problem.

Because of its lightweight composition, it can be cladded on load-bearing walls, steel, masonry, calcium silicate walls, or other partitioned material

Product Specifications

- It is manufactured from high-quality materials that are carefully selected. The material can withstand the harsh effects of adverse weather conditions.
- It is available in different forms and designs with a variety of colours to satisfy all tastes.
- It presents an ideal substance that isolates the outer surface from moisture and temperature.
- It is fastened to the construction of a substance strongly because its back surface is covered with excellent types of pebbles.
- It is lower in cost for traditional materials having comparable and to achieve similar design effect.
- It requires minimum maintenance as compared to other traditional construction materials.
- It is washable and can be easily cleaned.

Installation

There are many methods for fixing Bricks, but some are specified for bricks such as:

- Wet fix (Tile Adhesive)
- Wet fix (Cement Mortar)

Wet fixing with Tile Adhesive is one of the methods that is compatible with this kind of brick that is covered with chips of marble from its back side (fixing side). We recommend Tile Adhesive fixing for internal and external fixing for this project.

The steps for these methods are: -

- Water Curing.
- Adhesive application.
- Installation of bricks.
- Water Curing after fixing.
- Fill joints between the bricks with Good Hand SCF Grouts.

Packaging

Our Bricks come in individual packages containing material to install 1 m² area with weight of approximately 24 kg and can be carried easily.

Limited Warranty

Our products are free from manufacturing defects, Good Hand Stones and Concrete Flooring L.L.C does not warrant or guarantee the workmanship performed by any person/firm installing its products, unless that firm is in the list of our official applicator.

In no event shall Good Hand Stones and Concrete Flooring L.L.C be liable for any incidental or consequential damages.

Wet Fixing

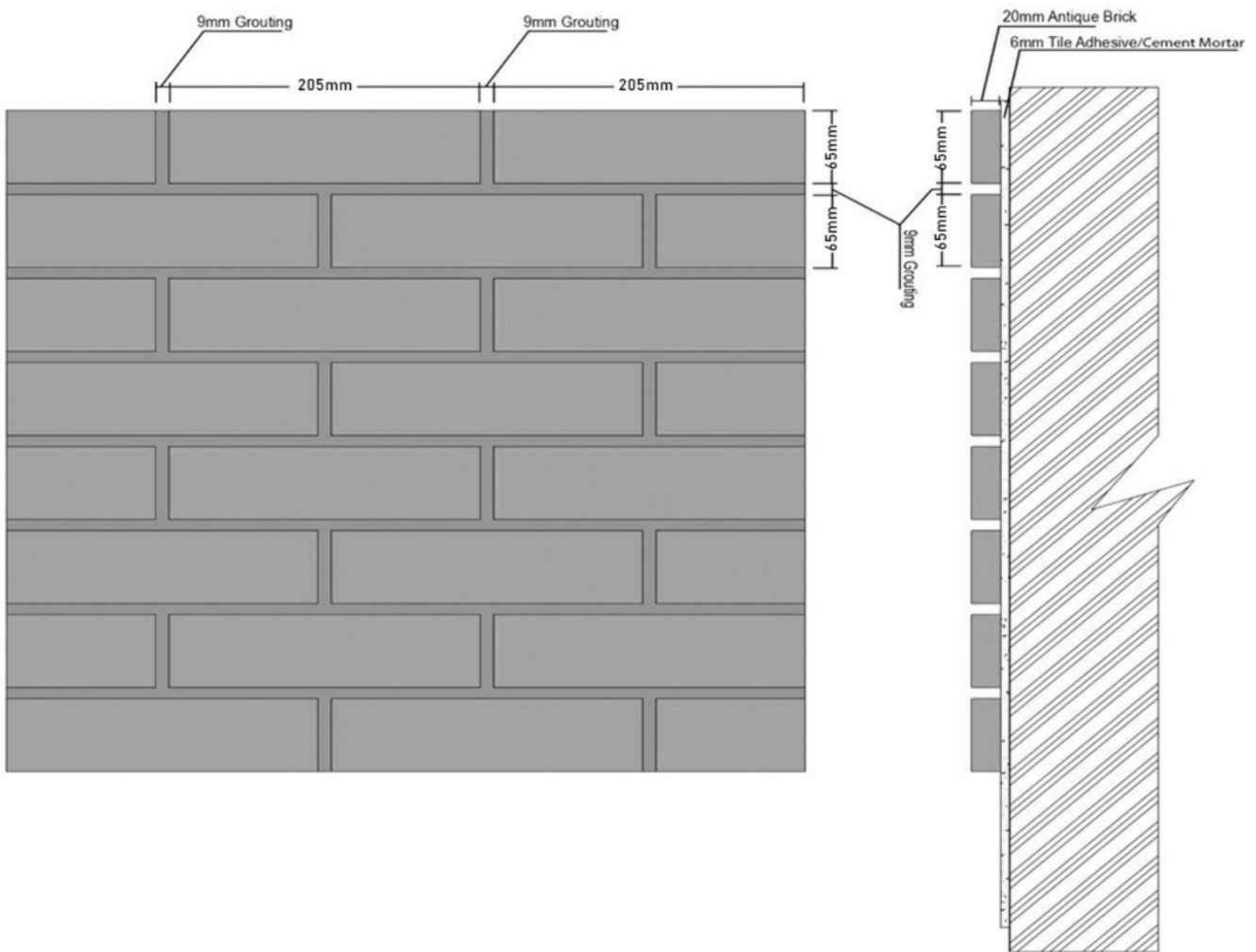

Materials Percentage

Material	Physical Specifications	Percentage
Chips marble	Solid	30%
White sand	Solid	15%
White Cement	Powder	30%
Silica sand	Solid	15%
Water, colors & chemicals	Liquid	10%

Testing

Water Absorption	1-2% depending on texture, to be tested further
Compressive Strength	Avg. 16.00 N/mm ² (can be modified)
Unit Weight of Antique Brick as DIM (205*65*15) mm	350:500 gm
Thermal Properties	U-value is 0.570 based on a (20mm) thick sample.
Non-combustible	Good Hand Stones and Concrete Flooring L.L.C brand products showed zero flame spread and zero smoke development.

How we turned

Dreams into Reality, Brick by Brick



Brick Work at Yas Mall Abu Dhabi





Brick Work Inside Ibn e Batuta Mall





Brick Work Inside The Galleria Mall





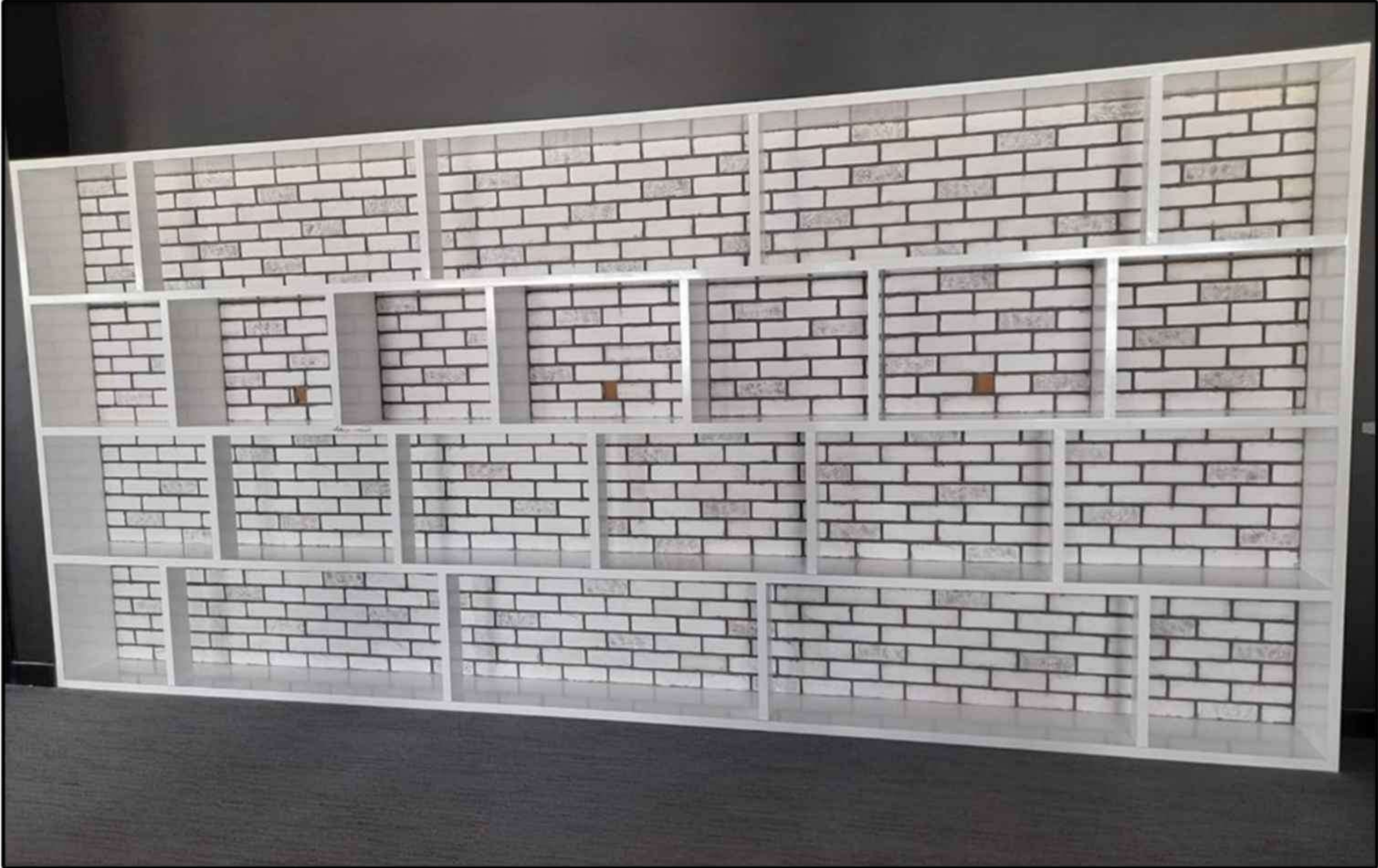

Brick Work at Meenar Cafe Jumierah Lake Towers



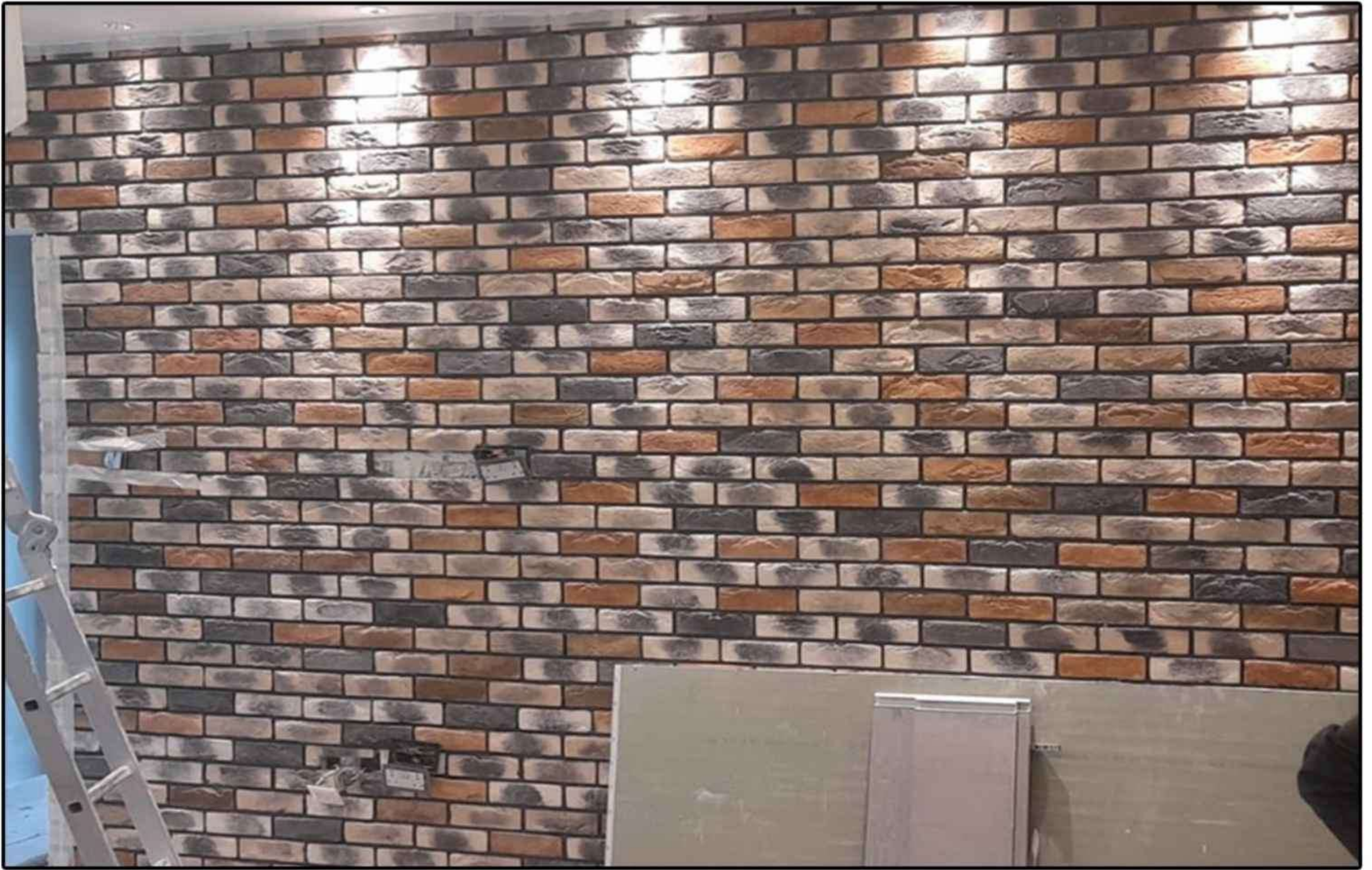

Brick Work at Anbar Resturant & Cafe in Business Bay

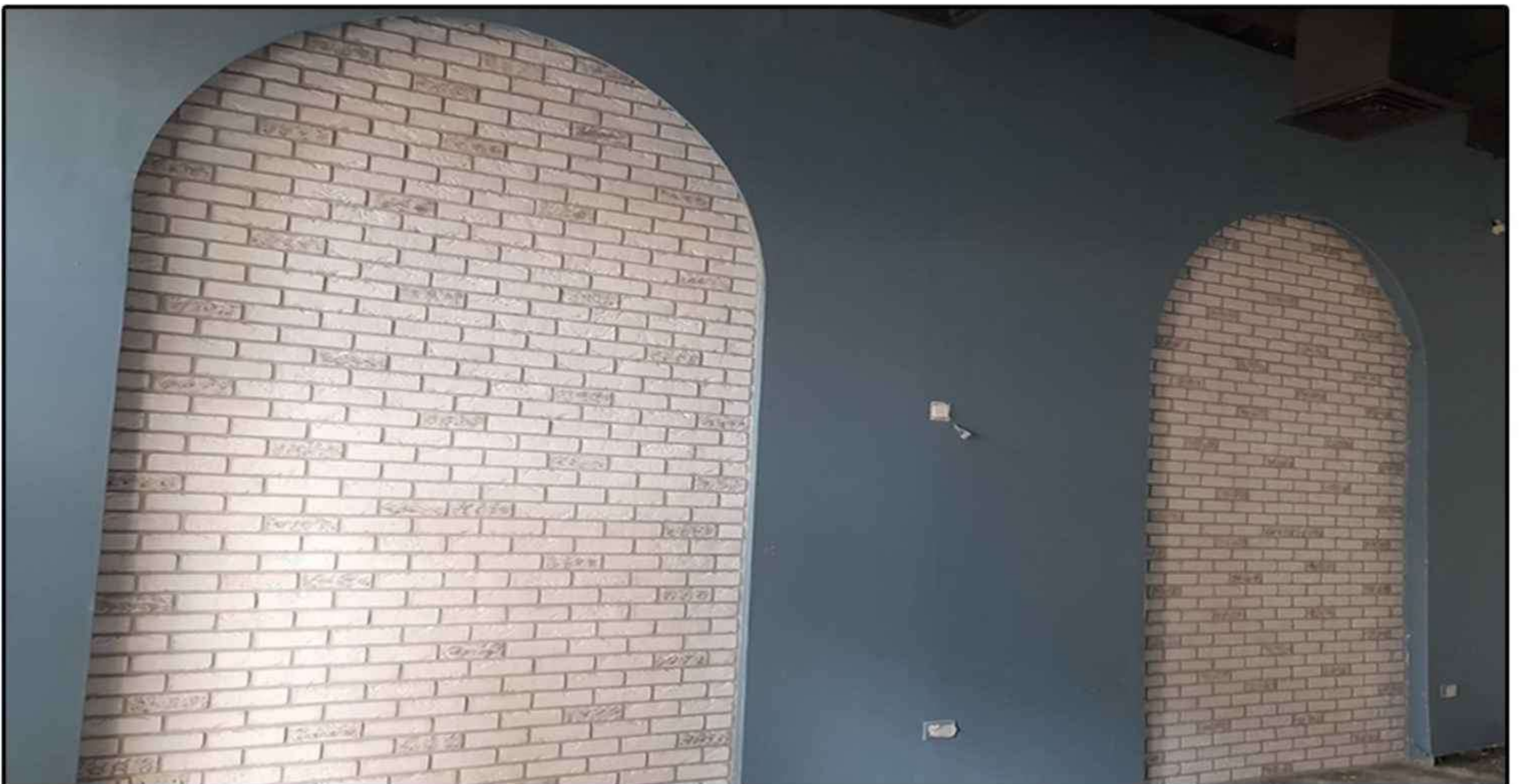

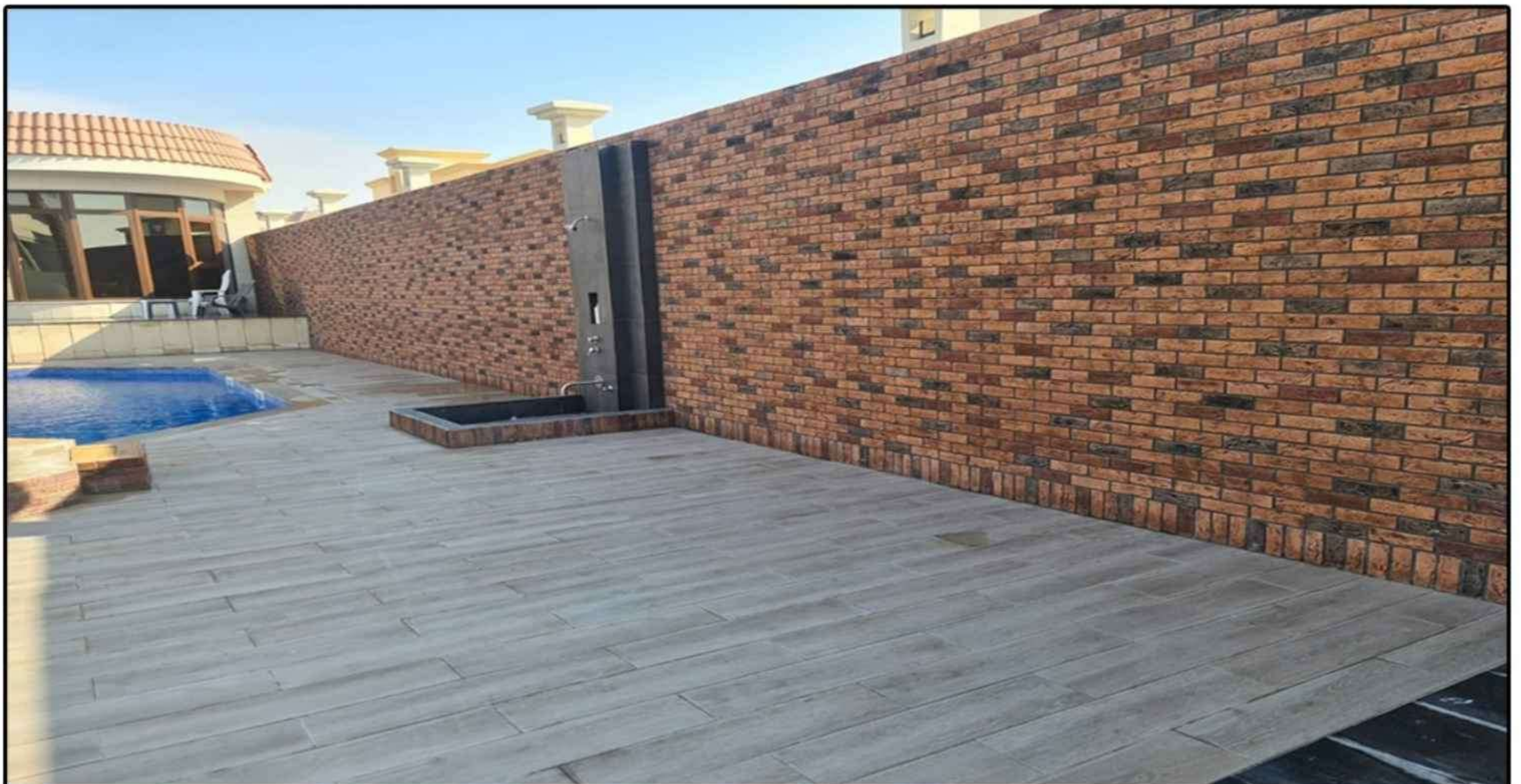
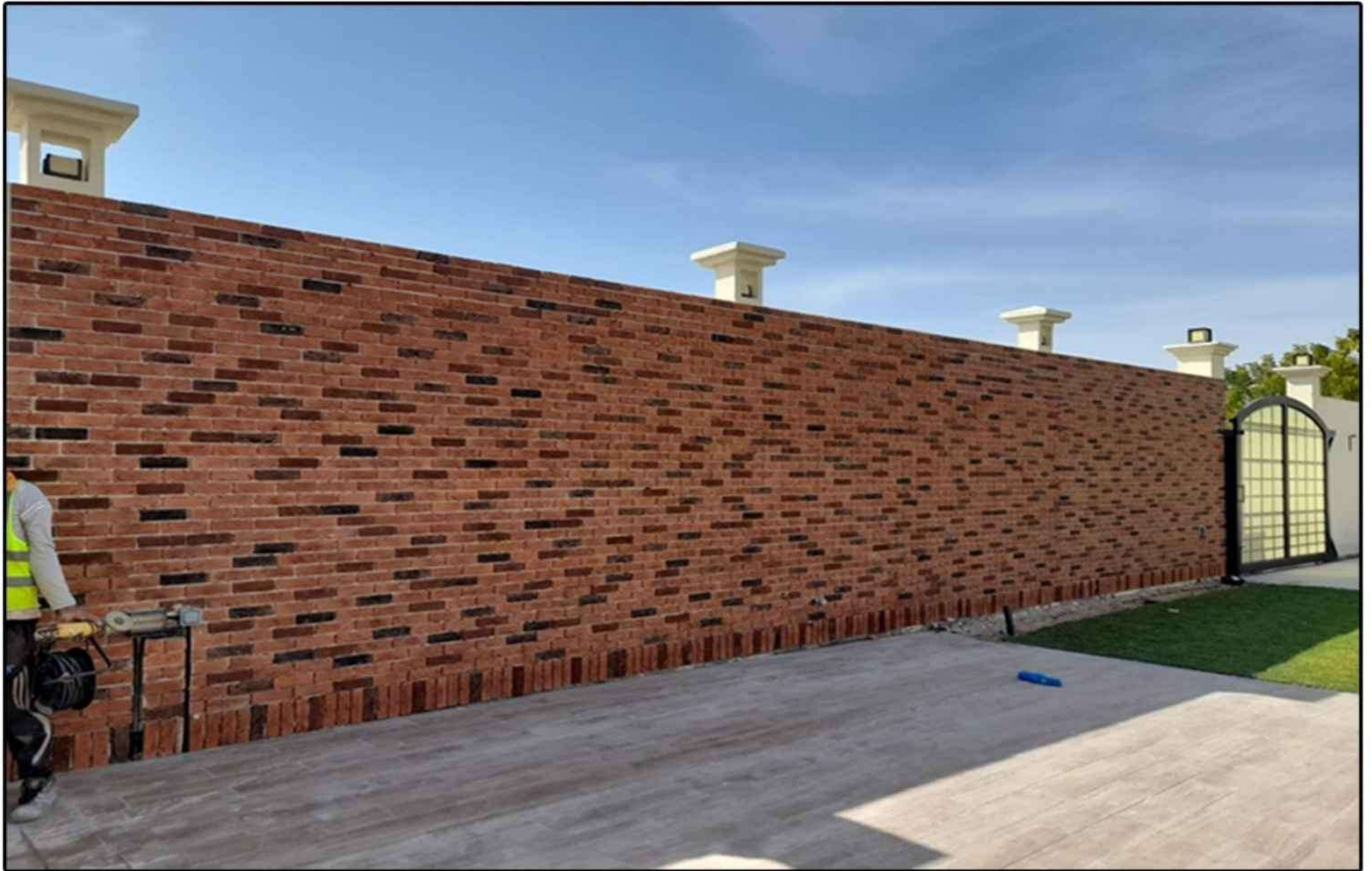

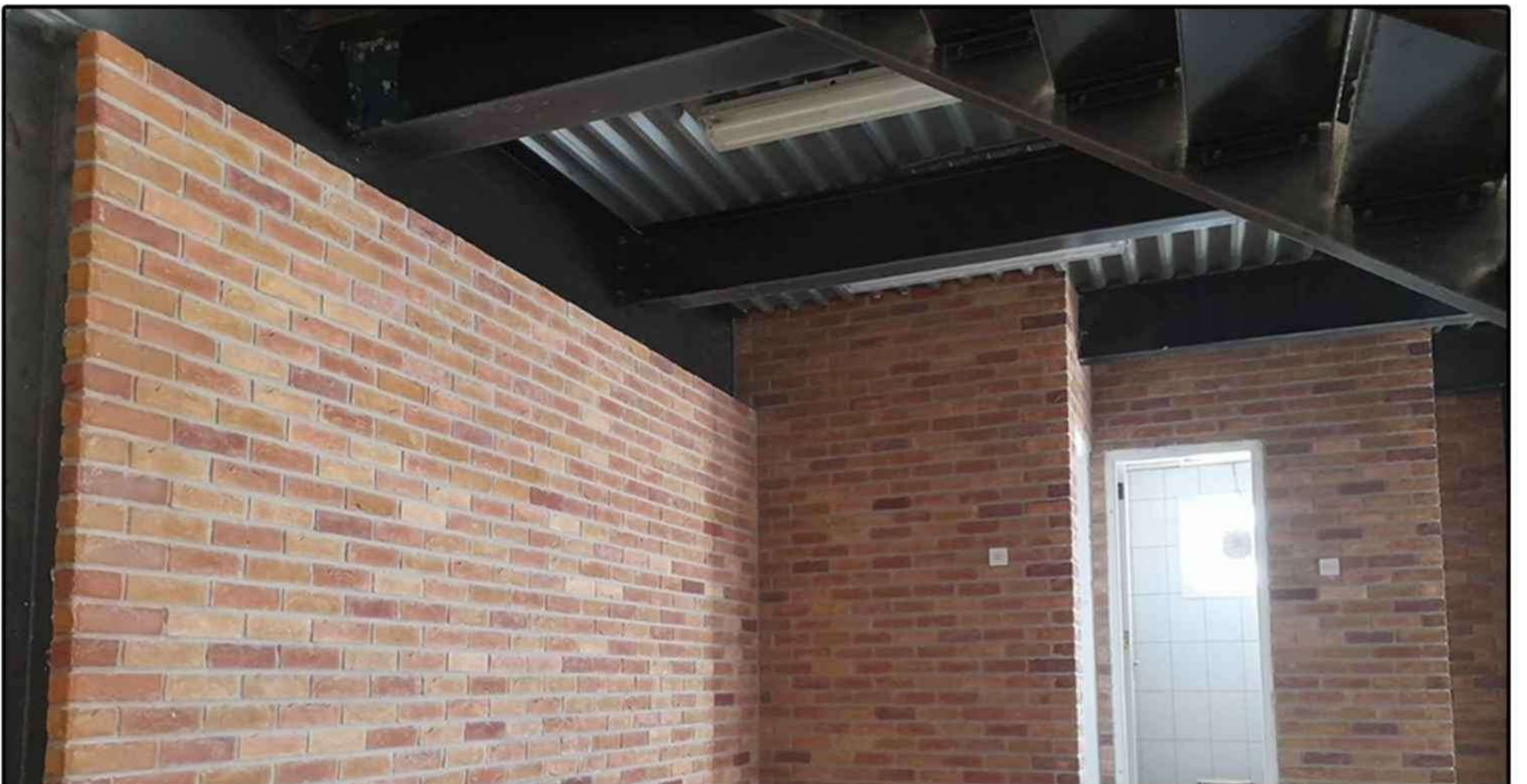

TOGETHER WE GROW

THANKYOU!

GOOD HAND STONES AND CONCRETE FLOORING L.L.C

Showroom 1, Al Falasi Building,

Salahaldin Street Deira, Dubai - UAE

Telephone: P: +971 (4) 262 2888

E mail: Sales@goodhandpro.com